

---

**PHYSICS**

**5054/31**

Paper 3 Practical Test

**October/November 2017**

**CONFIDENTIAL INSTRUCTIONS**

**Great care should be taken to ensure that any confidential information given does not reach the candidates either directly or indirectly.**

**No access to the Question Paper is permitted in advance of the examination.**

---

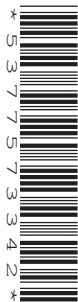

If you have any problems or queries regarding these Instructions, please contact Cambridge stating the Centre number, the nature of the query and the syllabus number quoted above.

e-mail            info@cie.org.uk  
phone            +44 1223 553554  
fax                +44 1223 553558

---

This document consists of **11** printed pages and **1** blank page.

## Instructions for preparing apparatus

These Confidential Instructions detail the apparatus required for each experiment in this paper. No access is permitted to the Question Paper in advance of the examination session.

## Number of sets of apparatus

In addition to a few spare sets, the minimum number of sets of apparatus to be provided should be sufficient to enable candidates to spend 20 minutes with the apparatus for each of Questions 1, 2 and 3, and one hour with the apparatus for Question 4. The order in which candidates answer the questions will be determined by the Supervisor. Candidates may spend one hour circulating around Questions 1, 2 and 3, followed by an hour on Question 4, or vice versa.

It is assumed that candidates will supply their own calculator and geometrical instruments, such as a set square,  $0^\circ$  to  $180^\circ$  protractor, pair of compasses and 30 cm ruler. Candidates should be advised in advance that they may, if they wish, use wristwatches with stopwatch facilities, providing that such wristwatches afford the required precision.

## Instructions for the supervision of the examination

The Supervisor, who may be a physics teacher, is responsible for the administration of the examination according to the procedures detailed in the Handbook for Centres. In all instances, a physics teacher should be present. Preferably, this teacher should have been responsible for the preparation of the apparatus. Two invigilators must be present at all times: it is not acceptable for a teacher who has been responsible for preparing the candidates for this paper to be the sole Supervisor or Invigilator.

Supervisors may make the following announcement at the start of the examination.

‘The Examiners do not want you to waste time if you are unable to do any experiment. Any candidate who is unable to get results with an experiment may ask for help. The extent of the help given will be reported to the Examiners, who may make a deduction of marks.’

Supervisors should note that a candidate may only be given enough assistance to allow some raw readings or observations to be made. On no account should any assistance be given with the treatment or analysis of these readings and observations.

Supervisors may draw to the attention of the candidates any significant deviation between the apparatus provided and that detailed in the Question Paper, particularly where diagrams are given in the paper.

Candidates should be reminded that all their work should be written on the Question Paper. Rough paper must not be used.

The Supervisor must complete the Report at the back of these Instructions. Details should be given of any significant deviation between the apparatus used and that specified in these Instructions. A sample set of results can often help Examiners. A copy of this Report must be included in **each** packet of scripts.

**Question 1****Items to be supplied by the Centre (per set of apparatus, unless otherwise specified)**

Three expendable steel springs, with a spring constant of approximately 25 N/m, e.g. Griffin catalogue number 12463080 or legacy number XBV-590-010H (see Note 1).

100 g mass hanger and four 100 g slotted masses (see Note 2).

Stand, boss and clamp to support the series spring arrangement and then the single spring.

Second clamp and boss to act as a fiducial marker.

Stopwatch, to a precision of at least 0.1 s.

**Notes**

1. The springs should be as identical as possible. Two of the springs are to be connected in series. This can be done by either passing a loop at the end of one spring through a loop at the end of the other spring in the same way that a key may be put on a key ring or by tying the loops together with a small length of string.
2. The slotted masses should be placed on the hanger and taped together. The total mass of 500 g should be labelled M.
3. At the changeover the Supervisor should dismantle any apparatus left set up by the candidate.

**Information required by Examiners**

Sample set of numerical results, clearly labelled "Supervisor's Results", obtained out of sight of the candidates.

## Question 2

### Items to be supplied by the Centre (per set of apparatus, unless otherwise specified)

4.5 V to 5 V d.c. power supply (see Note 1).

Switch or plug key.

Light-dependent resistor (see Note 2).

250 cm<sup>3</sup> glass beaker containing water (see Note 2).

Blu-tack (see Note 2).

Resistor of nominal value 2.2 k $\Omega$  (see Note 3).

Voltmeter capable of measuring a potential difference of up to 5.0 V to a precision of 0.1 V or better. An analogue or digital meter is suitable.

Connecting leads (see Note 4).

Light source and power supply (see Note 5).

10 cm<sup>3</sup> of blue liquid in a small container labelled A (see Note 6).

Safety glasses/goggles (see Note 6).

5 cm<sup>3</sup> plastic syringe (see Note 7).

Stirrer.

Paper towels or cloths to mop up spillages.

## Notes

1. The following are suitable power sources. All the candidates at a centre must be supplied with the same type of source:
  - three 1.5 V dry cells in suitable holders connected in series,
  - four 1.2 V rechargeable cells in suitable holders connected in series,
  - d.c. power supply of 4.5 V or 5 V.

If a variable d.c. power supply is used, the variable control should be taped to prevent candidates altering the output voltage.

2. A suitable light dependent resistor (LDR) is the NORPS 12. The RS component code of such an LDR is RS 914-6714. The LDR should be attached to the side of the glass beaker with Blu-tack. The light detecting face of the LDR should face into the beaker. The LDR should be about half way up the side of the beaker. The Blu-tack must **not** be between the light detecting face and the glass. The Blu-tack should be around the circumference of the LDR. The LDR may require long leads as the beaker will be separated from the remainder of the circuit. The ends of the leads should have suitable terminals to enable them to be connected into the remainder of the circuit. Once the LDR has been fixed to the beaker, the beaker should be filled with water to about 1 cm above the level of the LDR.

- The value of the resistor should be concealed from the candidates and the resistor should be labelled R. The resistor should have suitable terminals to enable it to be connected into the remainder of the circuit. The RS component code of a suitable resistor is RS 135-881.
- The Supervisor should set up the apparatus as shown in Fig. 2.1.

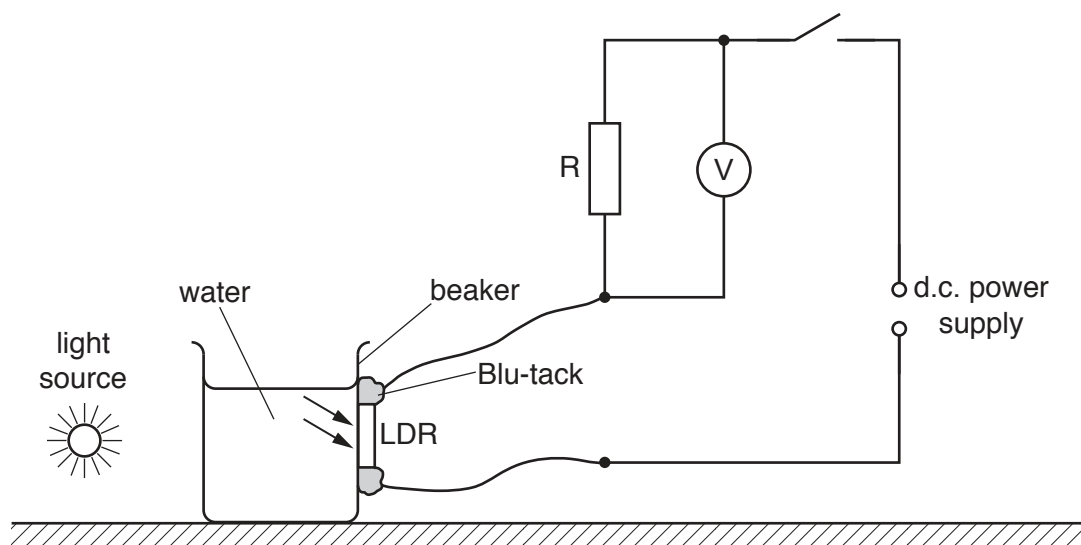

Fig. 2.1

- A suitable light source is a torch lamp of power rating approximately 0.5 W, placed a few centimetres from the beaker. The light source should be placed opposite the LDR. The light source should be facing and at the same height as the LDR. Supervisors should check that when the light is switched on the reading on the voltmeter is in the range 3 V to 4 V. If this is not the case then either the intensity of the light source, its distance from the LDR, or the value of the resistor R may be changed. A larger value of R will give a larger reading on the voltmeter.
- The blue liquid should be made by dissolving 0.1 g of methylene blue [HH] [MH] [N] in 200 cm<sup>3</sup> of water. Each candidate will only require a few cm<sup>3</sup> of the liquid. The liquid should be placed in a suitable small container close to the beaker of water on a paper towel. Candidates will be instructed to wash off this liquid if it comes into contact with their skin. They will also be instructed to wear safety glasses/goggles.
- This should be a non-sterile 5 ml plastic syringe without a locking function and **without a needle**. The syringe should have a graduated scale up to 5 ml. These are normally sold in packs of 100 by the scientific education companies. An example is Griffin Education catalogue number 12911031 (legacy number FB62336).
- At the changeover, the Supervisor should
  - remove the LDR from the side of the glass beaker,
  - pour away the now coloured solution in the glass beaker, rinse the beaker and refill the beaker with clean water,
  - dry the outside of the beaker and reattach the LDR (alternatively spare beakers of water may be prepared in advance with the LDR attached),
  - ensure that there is sufficient blue liquid for the next candidate,
  - ensure that the apparatus has been restored to its original state as in Fig. 2.1. If cells are used in the circuit, they should be checked and replaced, if necessary.

### Information required by Examiners

Sample set of numerical results, clearly labelled “Supervisor’s Results”, obtained out of sight of the candidates.

If a different value of R is used, Supervisors should record the value of the resistance used.

### Question 3

#### Items to be supplied by the Centre (per set of apparatus, unless otherwise specified)

Ramp (see Note 1).

Table tennis ball.

Fine dry sand (see Note 2).

Shallow tray to hold the sand (see Note 3).

Masking tape (see Note 3).

Two metre rules with mm divisions (see Note 3).

Stand, boss and clamp to support one of the metre rules vertically (see Note 3).

Set square.

Piece of stiff card, wide enough to smooth the sand in the tray.

#### Notes

- The ramp should be made of stiff wood and have a minimum length of 20 cm and a minimum width of 10 cm. A point P should be marked on the top face of the ramp, in the middle and 15.0 cm from the lower end, as shown in Fig. 3.1.

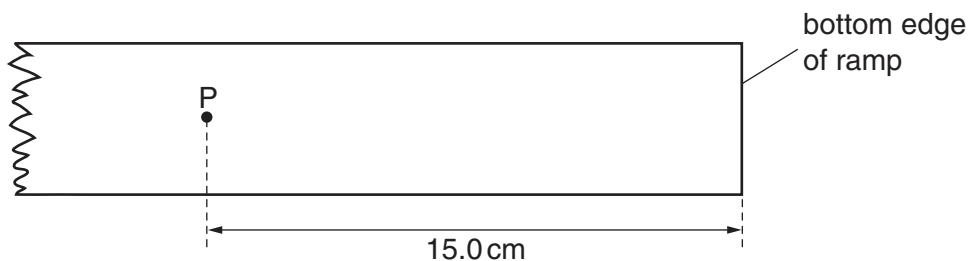
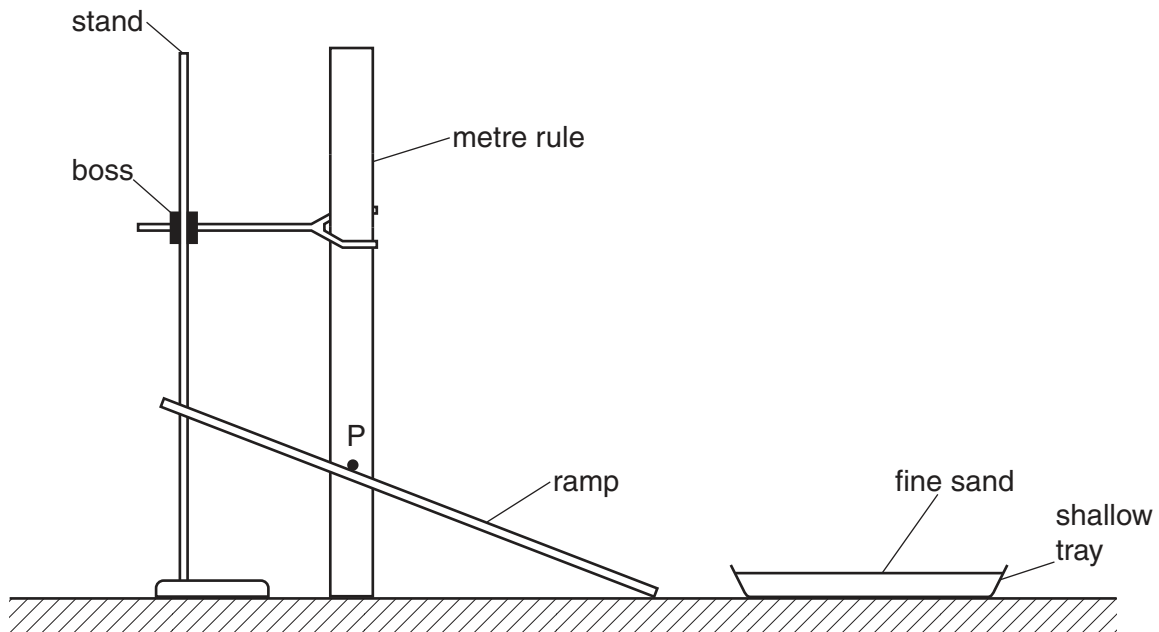

**Fig. 3.1**

The ramp should be inclined at an angle of approximately  $20^\circ$  to the horizontal. E.g. for a 20 cm ramp the top of the ramp should be supported about 6 cm above the bench or for a 100 cm ramp the top of the ramp should be supported about 30 cm above the bench. The lower end of the ramp should be resting on the bench.

- Any commercially available fine sand will do but it is important that the sand is dry. It may be necessary to dry the sand in an oven at low temperature. The table tennis ball will be dropped from a height of 30 cm onto the ramp at P. It will rebound to land in the sand. It is important that the table tennis ball will leave an imprint in the sand when this procedure is carried out.

3. The tray should be shallow so that the sides do not impede the motion of the table tennis ball when it rebounds from the ramp. The Supervisor should set up the apparatus as shown in Fig. 3.2. One of the metre rules should be clamped vertically, touching the back edge of the ramp behind point P.



**Fig. 3.2**

The Supervisor should try out the procedure described in Note 2 and place the tray in the correct position to receive the ball. The position of the tray should then be marked, e.g. with masking tape, so that it can easily be returned to this position at the changeover.

4. At the changeover the Supervisor should ensure that the apparatus is set up as in Fig. 3.2. The surface of the sand should be smooth and the other metre rule should be on the bench.

### Information required by Examiners

Sample set of numerical results, clearly marked “Supervisor’s Results”, obtained out of sight of the candidates.

#### Question 4

##### Items to be supplied by the Centre (per set of apparatus, unless otherwise specified)

Two expendable steel springs, with a spring constant of approximately 25 N/m, e.g. Griffin catalogue number 12463080 or legacy number XBV-590-010H (see Note 1).

Modelling clay (see Note 2).

Thin string of approximate length 50 cm (see Note 2).

S-hook.

Stand, boss and clamp to support the series spring arrangement (see Note 3).

100 cm<sup>3</sup> measuring cylinder.

30 cm ruler with mm divisions.

Beaker containing approximately 100 cm<sup>3</sup> of water.

Paper towels or cloths to mop up spillages.

#### Notes

1. The springs should be as identical as possible. The springs are to be connected in series. This can be done by either passing a loop at the end of one spring through a loop at the end of the other spring in the same way that a key may be put on a key ring or by tying the loops together with a small length of string.
2. The modelling clay should be rolled into a cylinder of diameter about 1 cm less than the internal diameter of the measuring cylinder. The length of the cylinder should be about 3 cm less than the internal height of the measuring cylinder. The ends of the cylinder should be flat and perpendicular to the sides of the cylinder. This can be achieved by trimming with a knife. The modelling clay should be rolled around the string so that the string passes along the axis of the cylinder. A loop should be made in the string protruding from one end. Any string protruding from the opposite end should be cut off.
3. Supervisors should ensure that the stand is sufficiently tall to support the series spring arrangement when it is loaded with the S-hook and the modelling clay.
4. The **candidate** will initially set up the apparatus as shown in Fig. 4.1 and then raise the clamp so that the modelling clay is suspended from the spring arrangement.



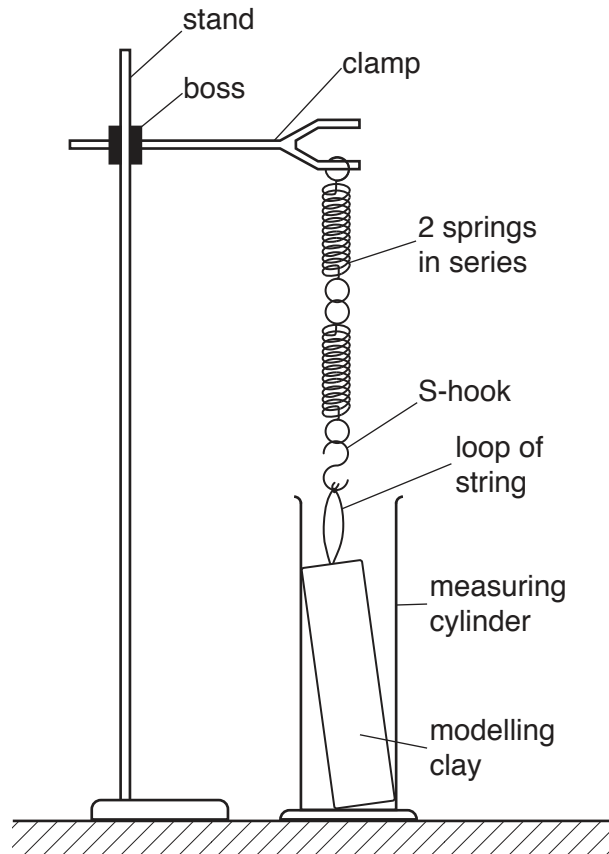

Fig. 4.1

5. At the changeover, the Supervisor should

- dismantle any apparatus left set up by the candidate,
- empty the water out of the measuring cylinder,
- ensure that there is sufficient water in the beaker for the next candidate.

### Information required by Examiners

Sample set of numerical results, clearly marked “Supervisor’s Results”, obtained out of sight of the candidates.

Permission to reproduce items where third-party owned material protected by copyright is included has been sought and cleared where possible. Every reasonable effort has been made by the publisher (UCLES) to trace copyright holders, but if any items requiring clearance have unwittingly been included, the publisher will be pleased to make amends at the earliest possible opportunity.

To avoid the issue of disclosure of answer-related information to candidates, all copyright acknowledgements are reproduced online in the Cambridge International Examinations Copyright Acknowledgements Booklet. This is produced for each series of examinations and is freely available to download at [www.cie.org.uk](http://www.cie.org.uk) after the live examination series.

Cambridge International Examinations is part of the Cambridge Assessment Group. Cambridge Assessment is the brand name of University of Cambridge Local Examinations Syndicate (UCLES), which is itself a department of the University of Cambridge.



**This form must be completed and returned with the candidates' scripts.**

### REPORT ON PRACTICAL PHYSICS

The Supervisor is asked to give the following details, using the space provided on page 12.

- (a) Information required at the end of the test, as indicated in the Instructions.
- (b) Any help given to a candidate.
- (c) Any general difficulties encountered in preparing the apparatus.
- (d) Any difficulties experienced by particular candidates. These should include reference to difficulties due to faulty apparatus or materials and accidental damage to apparatus or materials. Candidates should be identified by name and candidate number.

Other cases of hardship, such as disability or illness, should be reported to Cambridge in the normal way.

The Supervisor is asked to provide a plan of the work benches, giving details by candidate numbers of the places occupied by the candidates for each session. The plan and report should be enclosed in the envelope containing the candidates' scripts. If more than one envelope is used, a copy of the report must be enclosed in each envelope.

#### Declaration to be signed by the Supervisor

The preparation of this practical examination has been carried out so as to maintain fully the security of the examination.

Signed .....

Name (in block capitals) .....

Centre number .....

Centre name .....

**Information required**

For questions 1, 2, 3 and 4, please enclose a sample set of numerical results, obtained out of sight of the candidates and clearly labelled "Supervisor's Results".

**Details of difficulties and any help given to candidates**